



GARO Twinbox GTB

Assembly instructions / End User Instruction (EN)

Manual 380231 1.1



GARO AB

Box 203, SE-335 25 Gnosjö
Phone: +46 (0) 370 33 28 00
info@garo.se
garo.se



TABLE OF CONTENT

About this manual	3
INFORMATION	3
Warnings	3
Cautions	4
Notes	4
Content	5
INSTALLATION OF STANDALONE GTB TWINBOX	6
Remote enable signal	10
Dynamic Load Management (DLM) for Stand Alone GTB Twinbox	11
Dynamic Load Management (DLM) for GTB Twinbox in a grid	12
RFID reader installation	14
RFID settings for stand alone GTB Twinbox	15
RFID settings for GTB Twinboxes connected in a grid	15
LAN connection via RJ45	17
Electrical diagram	18
USER MANUAL	21
Normal use / Charging	21
Resetting/Conditioning of RCCB	22
Connecting to GTB Twinbox Wifi access point (AP)	23
Web interface	24
DLM settings (Dynamic Load Management)	27
RFID settings in the web interface	29
Connect GTB Twinbox to a local network via Wi-Fi	30
Connect GTB Twinbox to a local network via ethernet with DHCP	30
Connect GTB Twinbox to a local network via ethernet using static IP-address	30
Factory reset of Network settings	30
Updating the firmware	31
Care	32
Troubleshooting	33

About this manual

This document contains general descriptions which are verified to be accurate at the time of printing. However, because continuous improvement is a goal at GARO, we reserve the right to make product and software modifications at any time. This range is subject to continual product development. Errors, typo and omissions excepted.

Latest manual can always be found at <http://garemobility.com/support>

INFORMATION

GARO GTB assortment is a range of EVSE stations for Mode-3 AC charging.

Below are some example of standard features:

- Double outlets or cables for Mode-3 EV charging.
- Up to 2x22kW simultaneous charging from one EVSE depending on model.
- RCCB with DC-fault monitoring for each side.
- Internal static DLM (Dynamic Load Management).
- Remote control function for activated charging.
- Double mains terminals for easy forwarding of mains cable to next GTB.
- Suitable for installation on wall or pole.
- LED status indication.
- Upgradeable firmware

Some models also have:

- Energy meters for each side
- Communication module for Wifi/LAN functions
- RFID readers

General functions:

- Install and administrate RFID readers
- Connect mobile/tablet/PC to webinterface
- Activate scheduled charging via webinterface
- Schedule for electric current limitation via webinterface
- Install external energy-meter for advanced DLM
- Connect up to 16pcs GTB in a cluster for advanced DLM
- Update firmware via webinterface

Some functions require specific installed hardware ie communication module.

For full user manual: www.garemobility.com/support



Warnings



Dielectric Voltage Withstand Test is not allowed on GTB Twinbox



This equipment should not be used by anyone (including children) with reduced physical, sensory or mental capacity, or anyone lacking in experience or knowledge, unless they are provided with supervision or prior instruction in how to use the equipment by the person responsible for their safety.



The GTB Twinbox range of charging stations is designed exclusively for charging electric vehicles.



The GTB Twinbox must be grounded according to local country installation requirements.



Do not install or use the GTB Twinbox near flammable, explosive, harsh, or combustible materials, chemicals, or vapors.



Turn off the electrical power at the circuit breaker before installing, configuring or cleaning of the GTB Twinbox.



Use the GTB Twinbox only within the specified parameters.



Never spray water or any other liquid directly at the GTB Twinbox. Never spray any liquid onto the charge handle or submerge the charge handle in liquid. Store the charge handle in the dock to prevent unnecessary exposure to contamination or moisture.



Do not use this equipment if it appears to be damaged or if the charging cable appears to be damaged.



Do not modify the equipment installation or any part of the product.



Do not touch the terminals with fingers or any other objects.



Do not insert foreign objects into any part of the GTB Twinbox.

Cautions

- ⚠ Incorrect installation and testing of the GTB Twinbox could potentially damage either the vehicle's battery and/or the GTB Twinbox itself.
- ⚠ Felaktig installation och testning av GTB laddbox-serie kan skada bilbatteriet och/eller själva laddboxen.
- ⚠ Do not operate the GTB Twinbox in temperatures outside its operating range – see technical specifications.
- ⓘ To even out the load, it is important to rotate the phases when connecting several of GTB Twinboxes to the same supply. Note that 1-phase charging is common in electric vehicles and L1 and L2 in the GLB is used for this purpose.
- ⓘ Ventilation signal from EV is not supported.
- ⓘ Adapters for charging connectors are not allowed to be used.

Notes

- ⓘ All installation must be carried out by an authorised installer and comply with local installation regulations. If any questions, please contact your local electrical authority.
- ⓘ Ensure that the GTB Twinbox's charging cable is positioned so it will not be stepped on, driven over, tripped on, or subjected to damage or stress.
- ⓘ Unroll the charging cable to prevent it from overheating.
- ⓘ Do not use cleaning solvents to clean any of the GTB Twinbox's components. The outside of the GTB Twinbox, the charging cable, and the end of the charging cable should be periodically wiped with a clean, dry cloth to remove accumulation of dirt and dust.
- ⓘ Be careful not to damage the circuit boards or components during installation.
- ⓘ Refer to local standards and regulations not to exceed charging current limitations.
- ⓘ The front cover must always be locked in order to ensure compliance with IP Code IP44.
- ⓘ Avoid installing the GTB Twinbox in direct sunlight to avoid any heat-problems.
- ⓘ Electrical vehicles (EV) software and the GTB Twinbox firmware are continuously updated. To make sure that the GTB Twinbox is working properly, it is necessary to update the firmware and it requires a communication card. Communication cards are available as an accessory. GTB twinboxes installed in a cluster only need the master to have the communication card installed.
- ⓘ Cord extension sets for charging cable is not allowed to be used.

Content

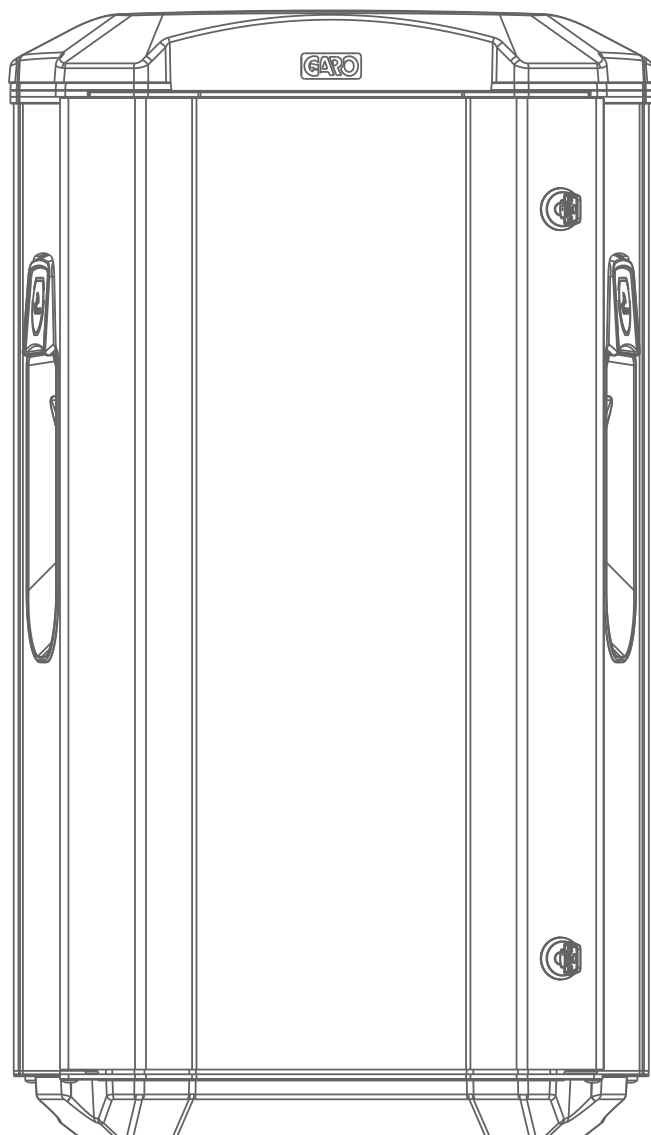

GTB Twinbox



Manual

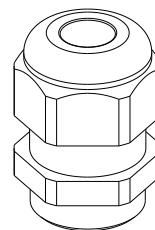

3X

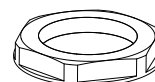

3X



Nycklar

INSTALLATION OF STANDALONE GTB TWINBOX

- Use conductors that are dimensioned in accordance with local electrical regulations. The selected cable must be able to sustain periods of constant load of up to 63A.
- The installation must be carried out by an authorized installer.
- Left hand side PCB (CC1) controls the left side outlet and right hand side PCB (CC2) controls the right hand side outlet.
- GTB Twinbox 1-phase models use L1 for left hand side outlet and L2 for right hand side outlet.

1. Select suitable group fuse and cable dimension for the electrical installation. Make sure to consider the cable length during calculation to avoid risk of voltage drop.

Table 1 shows the needed ampere (A) for each GTB Twinbox model.

Note: Due to high currents for a long time in the cable, there is a high risk of voltage drop if the cable is under-dimensioned which can damage the electronics in an EV.

2. Fill in the fuse and cable information in the Warranty form located in the installation manual that is included in the box.

3. Mount the GTB Twinbox on a wall or pole according to picture 1-6.

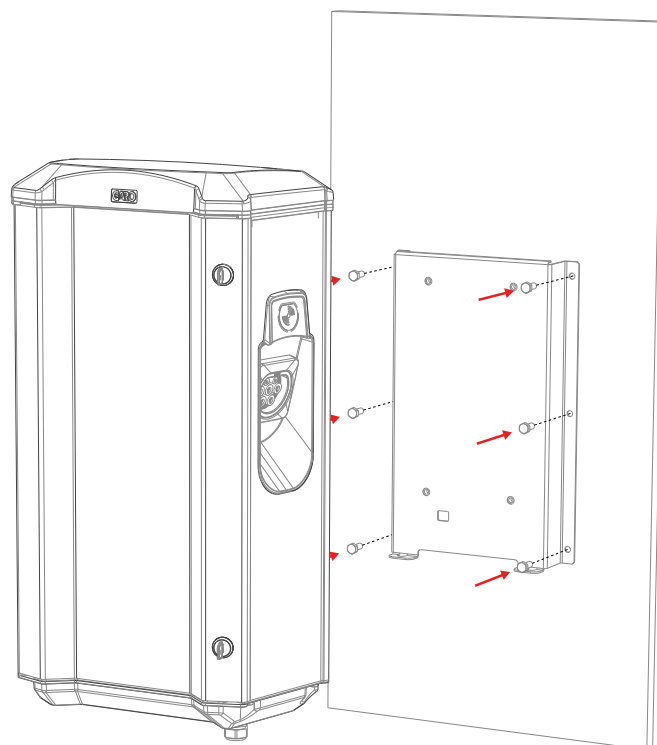

(picture 1)

6 Ø 8,5mm (screws not included)

GTB 3,7 kW = 16 A (L1, L2)
GTB 7,4 kW = 32 A (L1, L2)
GTB 11 kW = 32 A (L1, L2, L3)
GTB 22 kW = 63 A (L1, L2, L3)

(table 1)

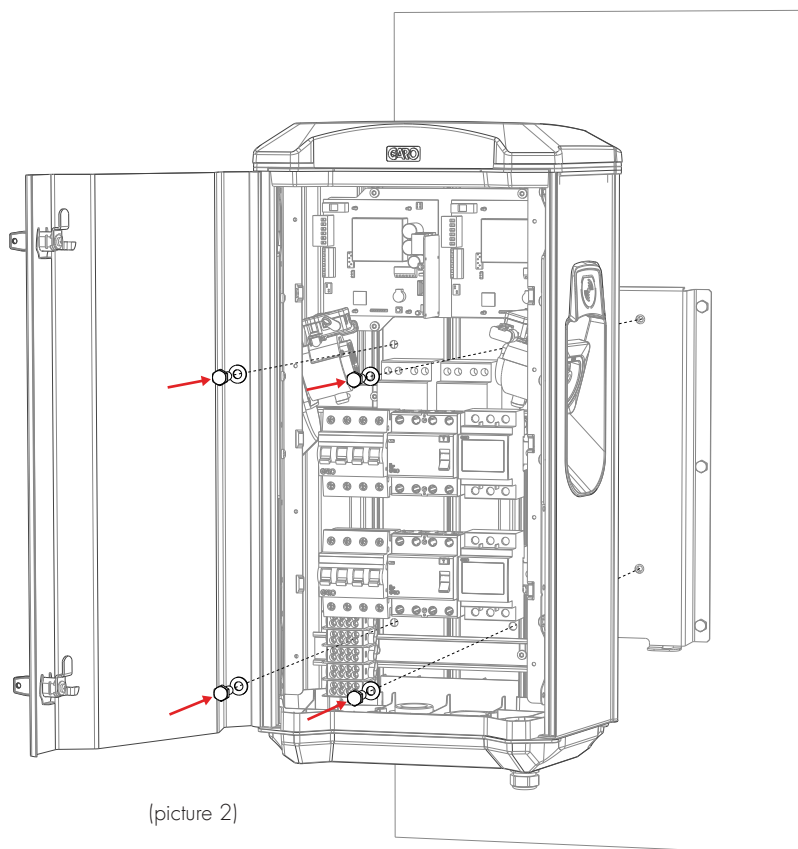

(picture 2)

4x M8 L20mm

INSTALLATION OF STANDALONE GTB TWINBOX

Note: Wall installation of GTB Twinbox requires a minimum 20mm distance between the wall and the GTB Twinbox to ensure correct cooling, see picture 3.

When GTB twinbox is installed on a pole, the holes at the back side of the GTB Twinbox should be covered/closed by attached screws, see picture 6.

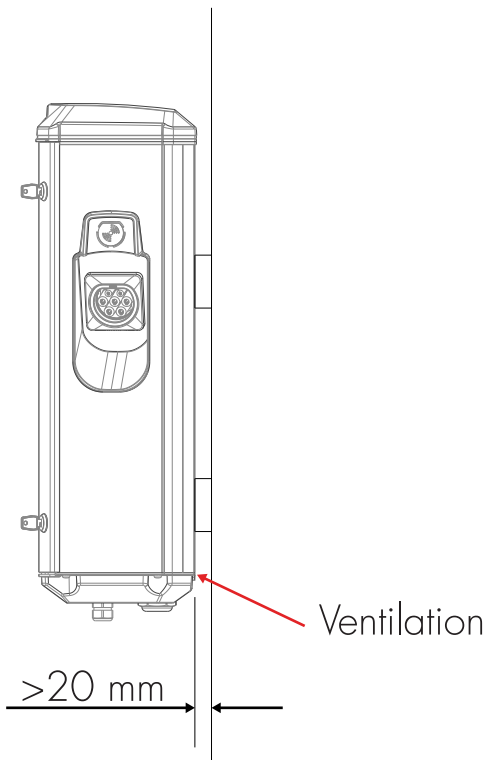

(picture 3)

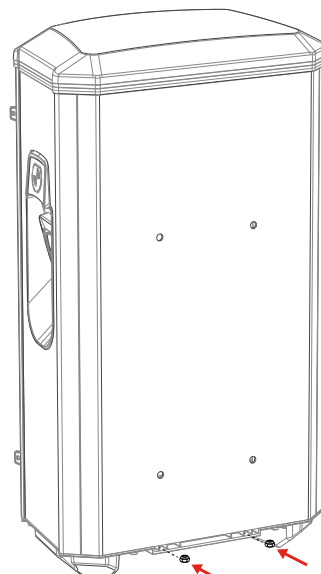

(picture 4)

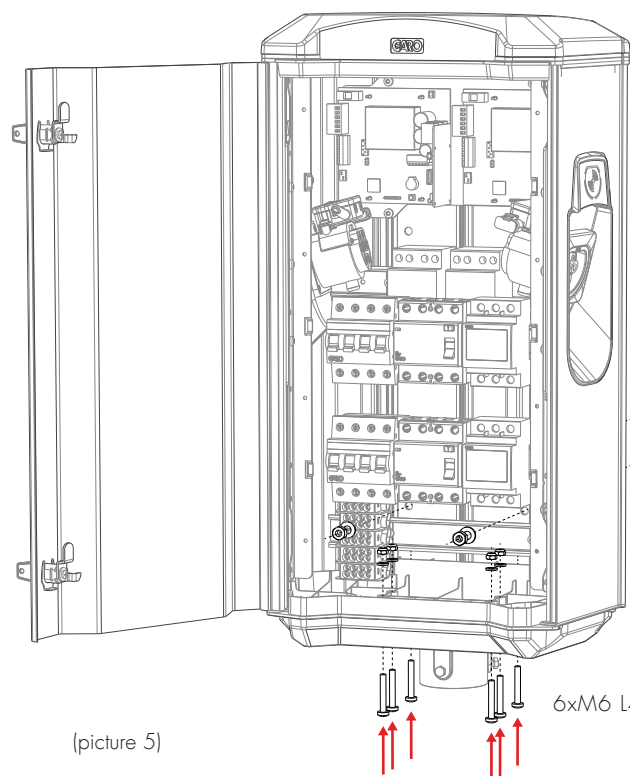

(picture 5)

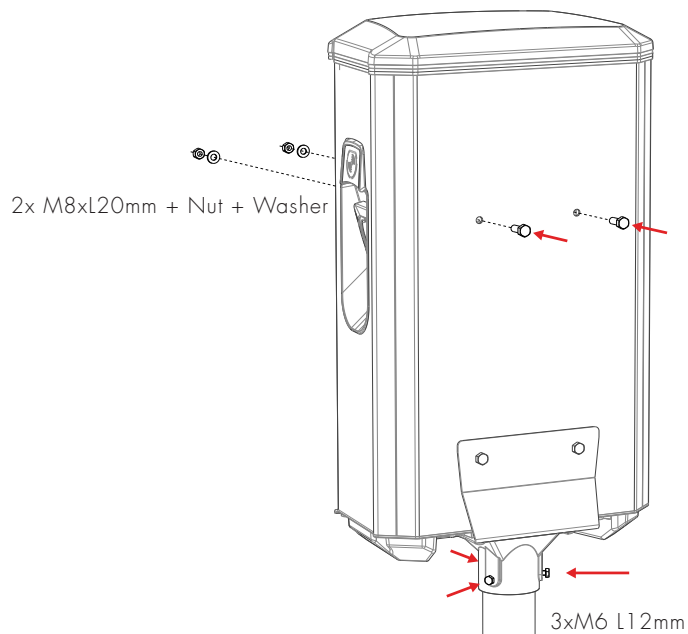

(picture 6)

INSTALLATION OF STANDALONE GTB TWINBOX

4. Check/set the dip 1-3 on SW1 CC2 to the max Ampere (A) that the outlets can load/charge, for example GTB11kW: 16+16A=32A

Dip switch SW1 is located in the center of left hand side of CC2, see picture 7.

5. With dip 1-3 on SW2 on both CC1 and CC2, you can (when needed) reduce the charge current (A) separate for left/ right hand side of the Twinbox. Available range is 6A – MAX32A, see picture 8. This is normally not necessary to do at a standard installation.

Note: it is ok to set different value for left and right hand side. SW2 on CC1 controls left hand side and SW2 on CC2 controls right hand side.

Dip switch SW2 is located at bottom left hand side on both CC1 and CC2, see picture 7.

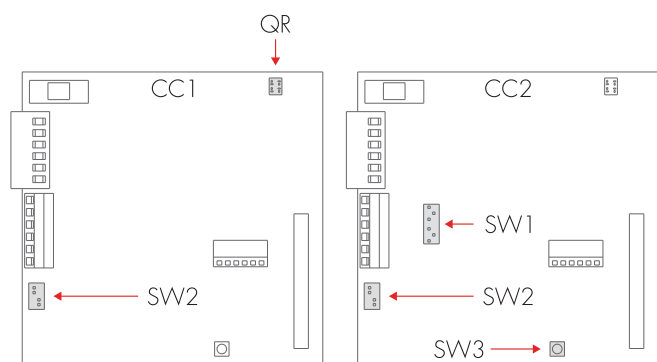

(picture 7)

SW1				SW2			
	ON	OFF		ON	OFF		
3	<input type="checkbox"/>	<input checked="" type="checkbox"/>	3=OFF	<input type="checkbox"/>	<input checked="" type="checkbox"/>	3=OFF	16A
2	<input type="checkbox"/>	<input checked="" type="checkbox"/>	2=OFF	<input type="checkbox"/>	<input checked="" type="checkbox"/>	2=OFF	
1	<input checked="" type="checkbox"/>	<input type="checkbox"/>	1=ON	<input checked="" type="checkbox"/>	<input type="checkbox"/>	1=ON	
3	<input type="checkbox"/>	<input checked="" type="checkbox"/>	3=OFF	<input type="checkbox"/>	<input checked="" type="checkbox"/>	3=OFF	20A
2	<input checked="" type="checkbox"/>	<input type="checkbox"/>	2=ON	<input checked="" type="checkbox"/>	<input type="checkbox"/>	2=ON	
1	<input type="checkbox"/>	<input checked="" type="checkbox"/>	1=OFF	<input type="checkbox"/>	<input checked="" type="checkbox"/>	1=OFF	
3	<input type="checkbox"/>	<input checked="" type="checkbox"/>	3=OFF	<input type="checkbox"/>	<input checked="" type="checkbox"/>	3=OFF	25A
2	<input checked="" type="checkbox"/>	<input type="checkbox"/>	2=ON	<input checked="" type="checkbox"/>	<input type="checkbox"/>	2=ON	
1	<input checked="" type="checkbox"/>	<input type="checkbox"/>	1=ON	<input checked="" type="checkbox"/>	<input type="checkbox"/>	1=ON	
3	<input checked="" type="checkbox"/>	<input type="checkbox"/>	3=ON	<input checked="" type="checkbox"/>	<input type="checkbox"/>	3=ON	32A
2	<input type="checkbox"/>	<input checked="" type="checkbox"/>	2=OFF	<input type="checkbox"/>	<input checked="" type="checkbox"/>	2=OFF	
1	<input type="checkbox"/>	<input checked="" type="checkbox"/>	1=OFF	<input type="checkbox"/>	<input checked="" type="checkbox"/>	1=OFF	
3	<input checked="" type="checkbox"/>	<input type="checkbox"/>	3=ON	<input checked="" type="checkbox"/>	<input type="checkbox"/>	3=ON	40A
2	<input type="checkbox"/>	<input checked="" type="checkbox"/>	2=OFF	<input type="checkbox"/>	<input checked="" type="checkbox"/>	2=OFF	
1	<input checked="" type="checkbox"/>	<input type="checkbox"/>	1=ON	<input checked="" type="checkbox"/>	<input type="checkbox"/>	1=ON	
3	<input checked="" type="checkbox"/>	<input type="checkbox"/>	3=ON	<input checked="" type="checkbox"/>	<input type="checkbox"/>	3=ON	50A
2	<input checked="" type="checkbox"/>	<input type="checkbox"/>	2=ON	<input checked="" type="checkbox"/>	<input type="checkbox"/>	2=ON	
1	<input type="checkbox"/>	<input checked="" type="checkbox"/>	1=OFF	<input type="checkbox"/>	<input checked="" type="checkbox"/>	1=OFF	
3	<input checked="" type="checkbox"/>	<input type="checkbox"/>	3=ON	<input type="checkbox"/>	<input checked="" type="checkbox"/>	3=OFF	63A
2	<input checked="" type="checkbox"/>	<input type="checkbox"/>	2=ON	<input type="checkbox"/>	<input checked="" type="checkbox"/>	2=OFF	
1	<input checked="" type="checkbox"/>	<input type="checkbox"/>	1=ON	<input type="checkbox"/>	<input checked="" type="checkbox"/>	1=OFF	
3	<input checked="" type="checkbox"/>	<input type="checkbox"/>	3=ON	<input checked="" type="checkbox"/>	<input type="checkbox"/>	3=ON	32A
2	<input checked="" type="checkbox"/>	<input type="checkbox"/>	2=ON	<input checked="" type="checkbox"/>	<input type="checkbox"/>	2=ON	
1	<input checked="" type="checkbox"/>	<input type="checkbox"/>	1=ON	<input checked="" type="checkbox"/>	<input type="checkbox"/>	1=ON	

(picture 8)

INSTALLATION OF STANDALONE GTB TWINBOX

Note: Dip 1-3 SW2 settings on both CC1 and CC2 MAX Ampere (A), see table 2.

6. Install the electrical supply cable to terminals L1-L3, N, PE.

Note: GTB twinbox is equipped with double terminals that makes it easy to forward the supply cable to another GTB Twinbox, see picture 9.

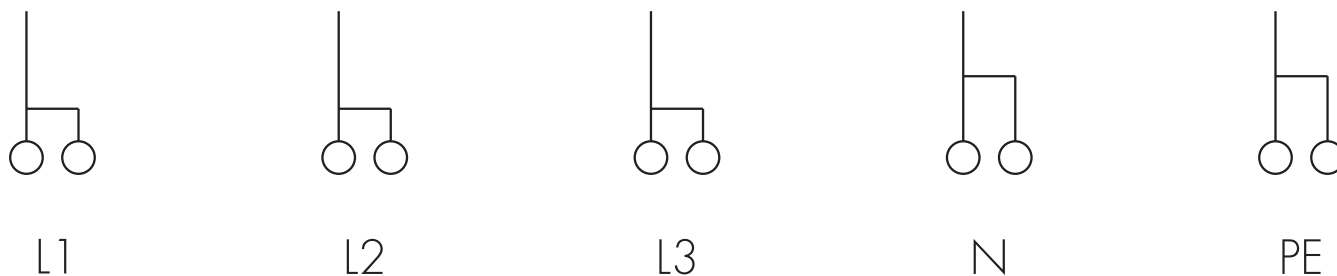

(picture 9)

7. Fill in the serial number in the Guarantee form. See QR code label at upper right corner of CC1, see picture 7.

8. Assembly the front cover and close the front door, see picture 10.

9. Turn on electrical power.

10. For GTBDCW... models: Connect a mobile device (PC/ Tablet/Mobile) to the GTB Twinbox Wifi network. You find SSID and password on a label inside the front door. Type in 172.24.1.1 in your web browser and check that the GTB web interface is visible. This action confirms that the GTB Twinbox wifi module is working properly.

11. Test the GTB twinbox with a test instrument or test to charge an electric vehicle to ensure that the GTB twinbox is working properly.

12. Doublecheck that the Warranty Form is filled in completely, sign with name, date and company that the warranty is valid. Note that the GTB Twinbox need to be powered on for around 15min before this action.

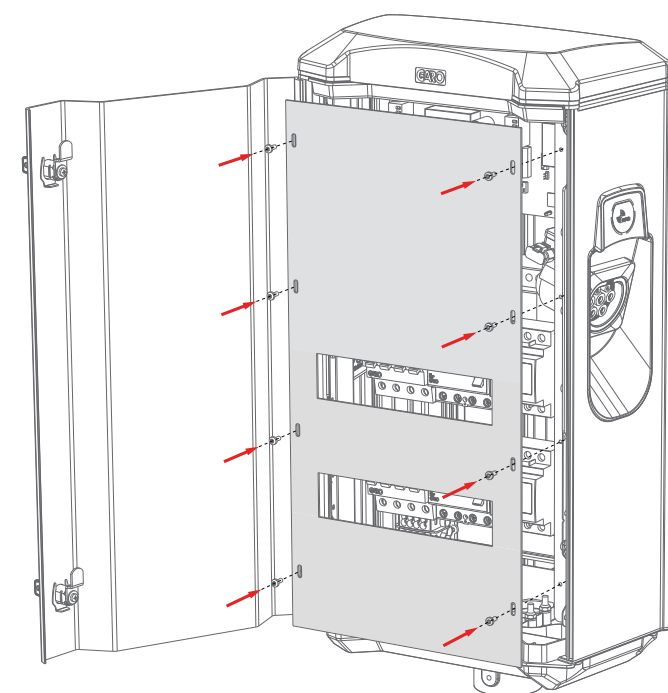

(picture 10)

Max current (A) for each side and model

GTB 3,7 kW = MAX 16 A
GTB 7,4 kW = MAX 32 A
GTB 11 kW = MAX 16 A
GTB 22 kW = MAX 32 A

(table 2)

Remote enable signal

Via a potential-free contact (relay, timer etc) the GTB Twinbox can be remotely enabled/disabled. The cable is connected to terminals on CC2, see picture 11 (remote control).

Enable of the GTB Twinbox can be done in two ways:

1. Enable by open circuit (default from factory).
2. Enable by closed circuit.

The setting is done via SW1 DIP4 on CC2, see picture 12

ON = Open circuit enables GTB Twinbox (default)

OFF= Closed circuit enables GTB Twinbox

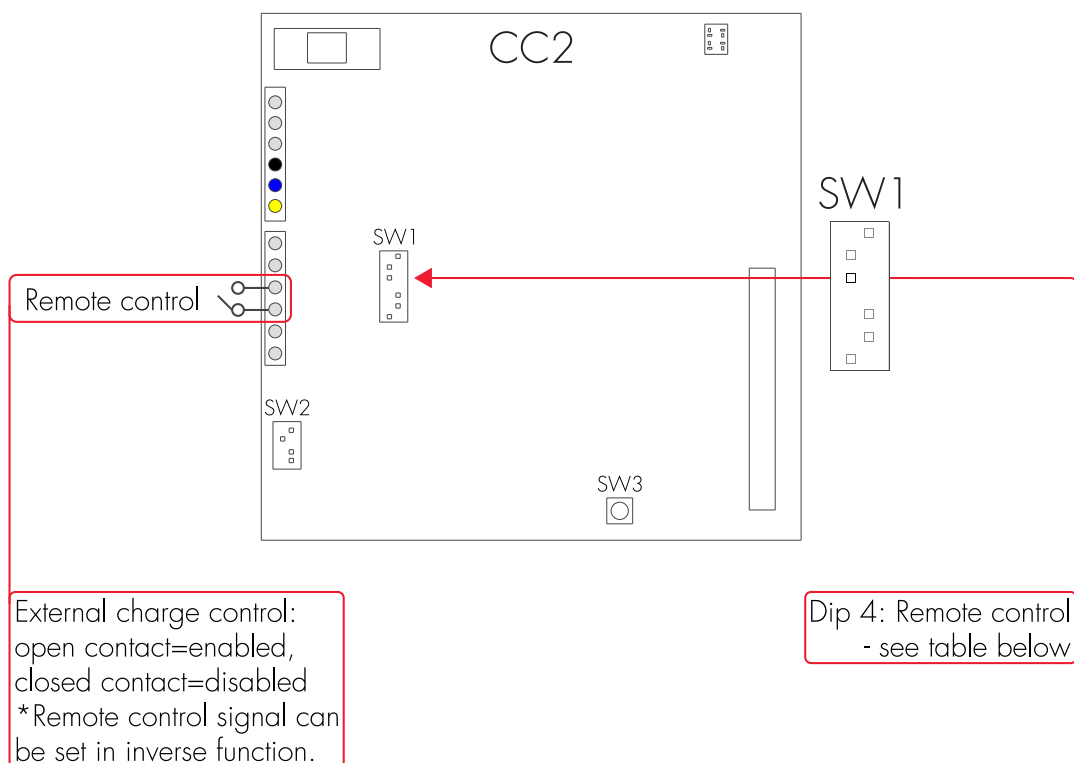

(bild 11)

Dynamic Load Management (DLM) for Stand Alone GTB Twinbox

DLM reduces charging current when demand of current elsewhere increases. Simple to say, the GTB Twinbox balance the charging current that you will get as much power as possible to the EV that is available in the system without any risk to overload the mains fuses.

To activate DLM, a Modbus energy meter must be installed in the supply distribution box. The following energy meters are approved:

- Garo GNM1D-RS485
- Garo GNM3D-RS485 (current transformer 3-phase. Max current is based on current transformer)
- Garo GM3T-RS485
- Garo GNM3T-RS485
- CG EM 112
- CG EM 270
- CG EM 271

For use in systems that have local electricity production (solar cell, wind etc)

Garo GNM3D-LP-RS485 (current transformer 3-phase. Max current is based on current transformer)Garo GNM3T-LP-RS485

Note the energy meter's Modbus address must be set to 2, 100 or 101.

Adress 2: Recommended for a stand alone GTB Twinbox. Setting for SW1 CC2 is valid and charging process are paused if available current drops below 6A.

Adress 100 or 101: Only recommended when multiple GTB Twinboxes are connected in a grid. Minimum charging current is 6A and charging process is not terminated by the DLM function. This mode require an installed wifi module.

The energy meter continually measures the total energy consumption for each phase. The data is transmitted to the GTB Twinbox, that then is reducing the charging current when necessary in order to prevent the mains fuses from tripping.

In one-phase systems, the energy meter needs to be installed to same phase as the GTB Twinbox.

Connection of the energy meters Modbus cable:

Terminal 200: A -
Terminal 201: B +

Recommended cable is twisted pair shielded signal cable approved for Modbus communication.

Settings in the Energy meter:

- Modbus address 2 (recommended), 100 or 101 (9600 baud, no parity, one stop bit).
- Set SW2 (Dip 1-3) CC2 to max available Ampere (A) (see settings for max available Ampere from mains)

	ON	OFF		ON	OFF		ON	OFF		ON	OFF		ON	OFF		ON	OFF	
3	<input type="checkbox"/>	<input checked="" type="checkbox"/>	3	<input type="checkbox"/>	<input checked="" type="checkbox"/>	3	<input type="checkbox"/>	<input checked="" type="checkbox"/>	3	<input checked="" type="checkbox"/>	<input type="checkbox"/>	3	<input checked="" type="checkbox"/>	<input type="checkbox"/>	3	<input checked="" type="checkbox"/>	<input type="checkbox"/>	
2	<input type="checkbox"/>	<input checked="" type="checkbox"/>	2	<input checked="" type="checkbox"/>	<input type="checkbox"/>	2	<input checked="" type="checkbox"/>	<input type="checkbox"/>	2	<input type="checkbox"/>	<input checked="" type="checkbox"/>	2	<input checked="" type="checkbox"/>	<input type="checkbox"/>	2	<input checked="" type="checkbox"/>	<input type="checkbox"/>	
1	<input checked="" type="checkbox"/>	<input type="checkbox"/>	1	<input type="checkbox"/>	<input checked="" type="checkbox"/>	1	<input checked="" type="checkbox"/>	<input type="checkbox"/>	1	<input type="checkbox"/>	<input checked="" type="checkbox"/>	1	<input checked="" type="checkbox"/>	<input type="checkbox"/>	1	<input type="checkbox"/>	<input checked="" type="checkbox"/>	
	16 A		20 A		25 A		32 A		40 A		50 A		63 A					

(bild 12)

Dynamic Load Management (DLM) for GTB Twinbox in a grid

To activate DLM for GTB Twinboxes installed in a grid, a Modbus energy meter must be installed in the supply distribution box. It is also possible to install a 2nd Modbus energy meter when you need to measure the consumed energy at more than one place.

The following energy meters are approved:

- Garo GNM1D-RS485
- Garo GNM3D-RS485 (current transformer 3-phase. Max current is based on current transformer)
- Garo GM3T-RS485
- Garo GNM3T-RS485
- CG EM 112
- CG EM 270
- CG EM 271

For use in systems that have local electricity production (solar cell, wind etc)

Garo GNM3D-LP-RS485 (current transformer 3-phase. Max current is based on current transformer)

Garo GNM3T-LP-RS485

Note the energy meter's Modbus address must be set to #100 (and #101 for a 2nd e-meter).

The energy meter/meters continually measures the total energy consumption for each phase. Data is transmitted to the first wallbox (GTB Master), which controls the charging current per phase for the entire system in order to prevent the main fuses from tripping.

The Master GTB in the grid needs to have a wifi module installed.

A maximum of 16 GTB Twinbox may be connected together in a grid by a shielded twisted pair cable. See picture 13, 14.

It is allowed to mix GTB Twinbox with GLB Wallbox in this type of grid, and the limit is max 32pcs "outlets", (GTB = 2pcs outlets and GLB = 1 pcs outlet).

Schematic image with Twinbox placed to the left of the cluster

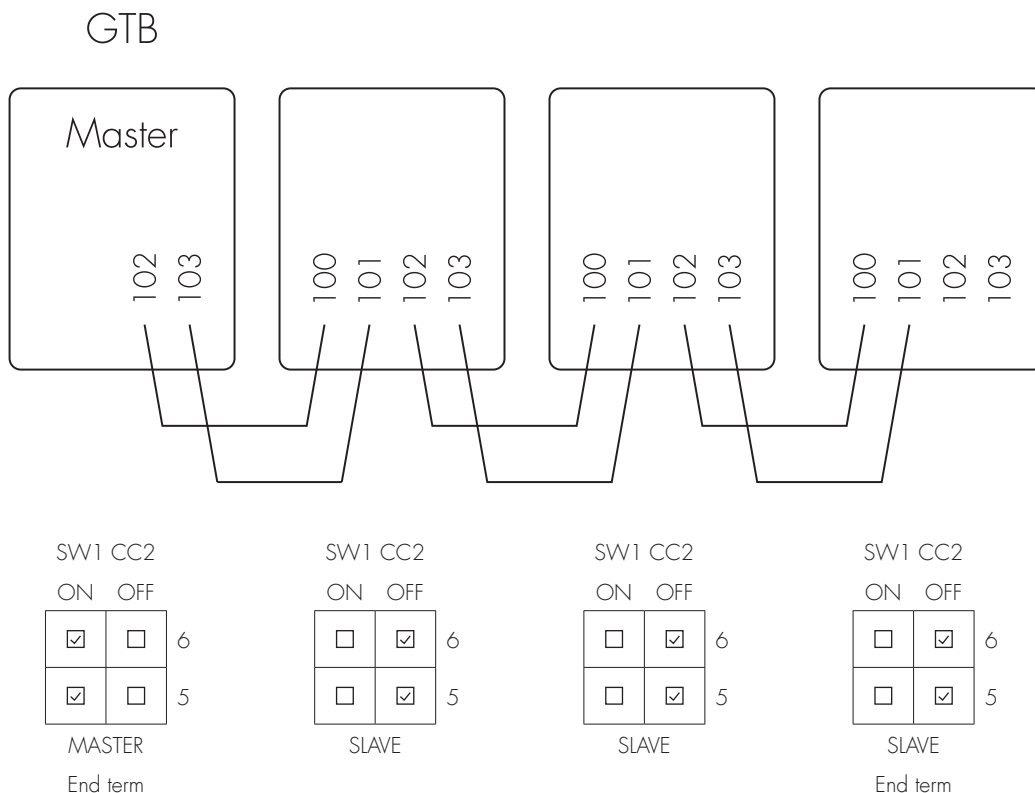

(picture 13)

INSTALLATION OF STANDALONE GTB TWINBOX

The first GTB Twinbox in the grid will be the "Master" in the installation and it is set by SW1 Dip 5 on CC2. All other units in the grid should be "slaves" set by SW1 Dip 5 on CC2.

First and last GTB Twinbox in the grid should be "end-terminated" and this is set by SW1 Dip 6 on CC2.

Schematic image with Twinbox placed in the center of the cluster

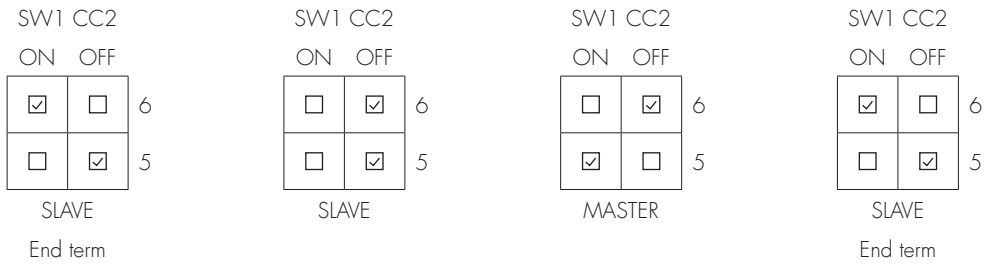
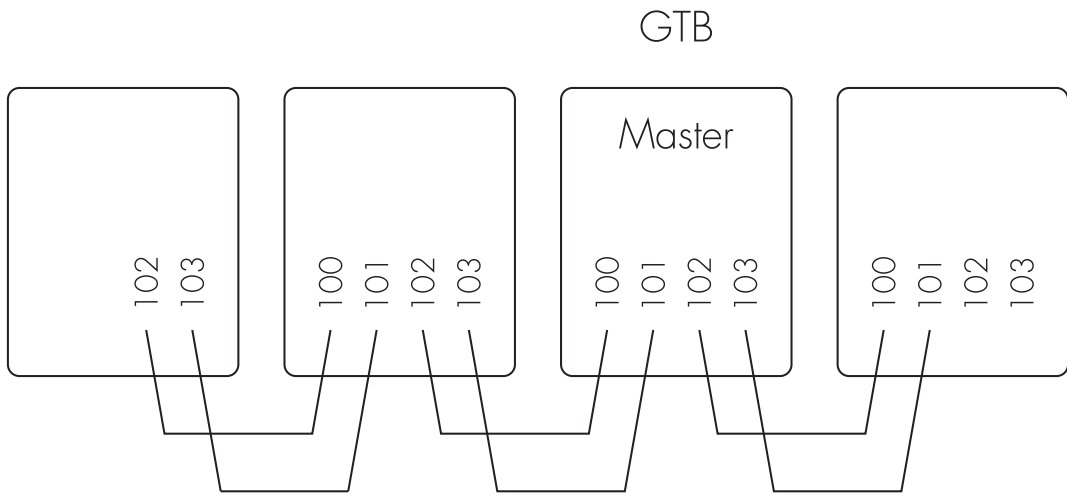

(picture 14)

Settings explanation of Dip 5, 6 on SW1 CC2



(table 3)

RFID reader installation

- 1. Turn off the electrical power to the GTB twinbox
- 2. Assembly the RFID readers according picture 15-17.

DIP switch	ON	OFF	
	<input checked="" type="checkbox"/>	<input type="checkbox"/>	2
	<input checked="" type="checkbox"/>	<input type="checkbox"/>	1

Note: Both DIP switches should set to ON on both RFID readers, see picture 18.

A wifi module needs to be installed to the Master GTB Twinbox.

(picture 15)

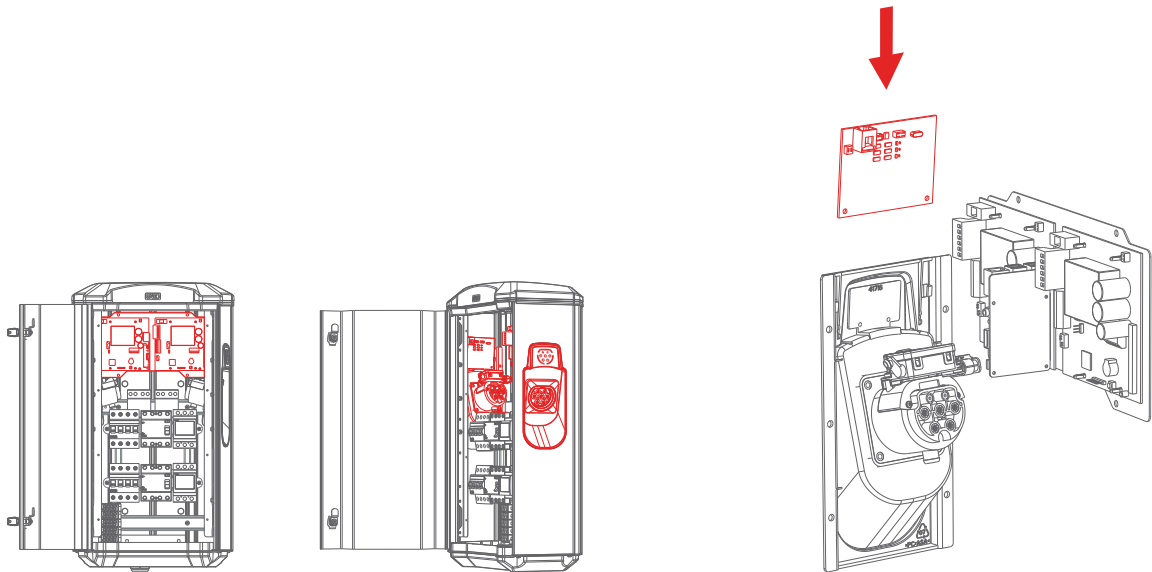

(picture 16)

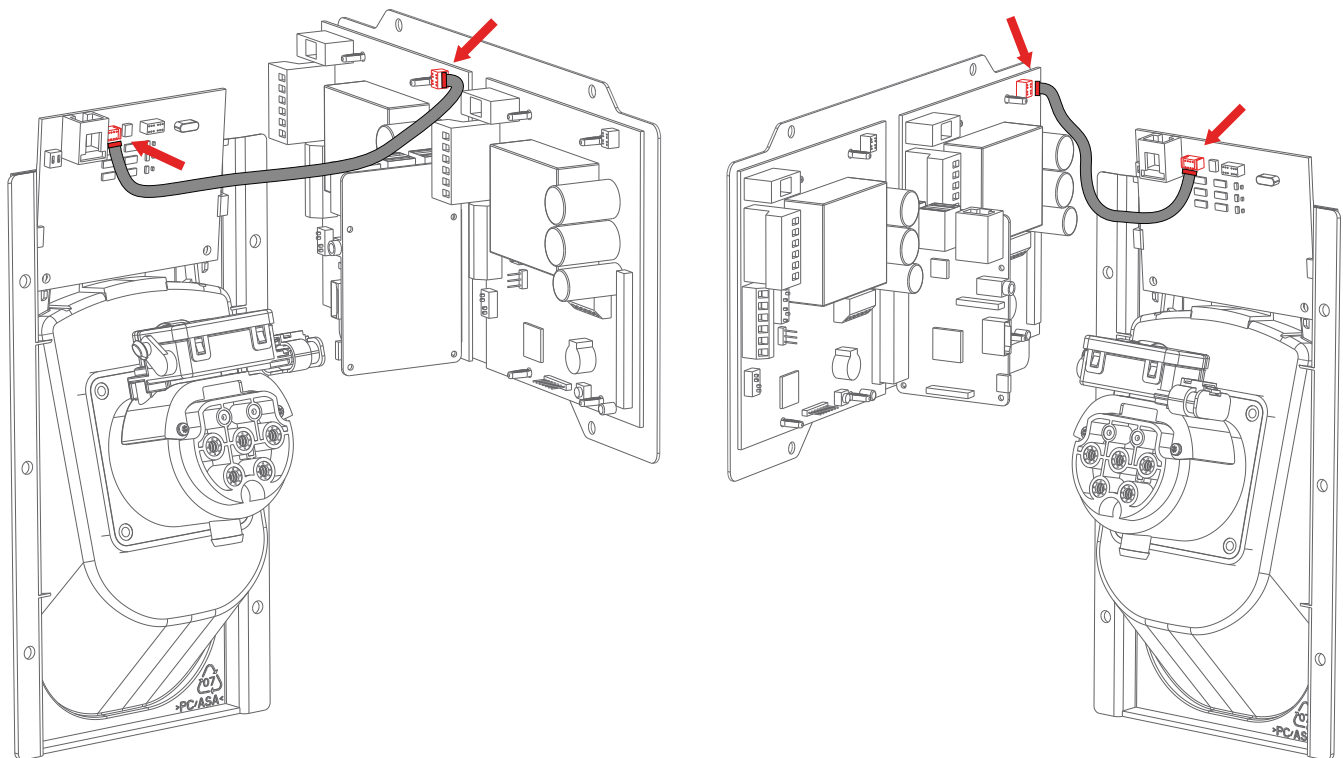

(picture 17)

(picture 18)

RFID settings for stand alone GTB Twinbox

Set SW1 (Dip5) CC2 to ON that makes the unit as "Master", see picture 19.

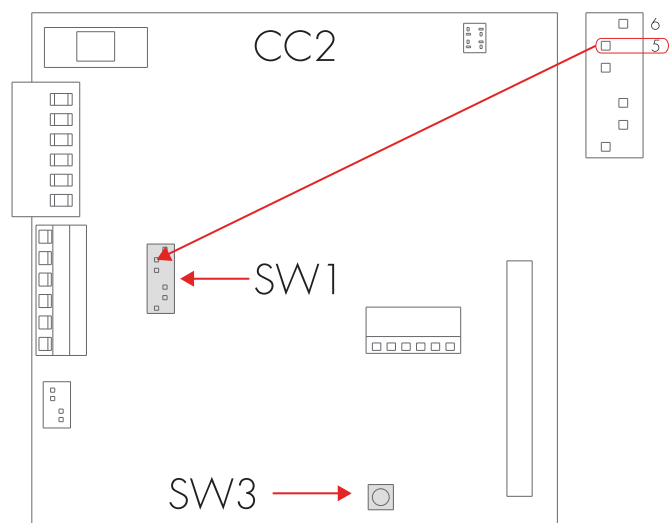

(picture 19)

RFID settings for GTB Twinboxes connected in a grid

A maximum of 16 GTB Twinbox may be connected together in a grid by a shielded twisted pair cable, see picture 20, 21

It is allowed to mix GTB Twinbox with GLB Wallbox in this type of grid, and the limit is 32pcs "outlets", (GTB = 2pcs outlets and GLB = 1 pcs outlet).

The first GTB Twinbox in the grid will be the "Master" in the installation and it is set by SW1 Dip 5 on CC2. All other units in the grid should be "slaves" set by SW1 Dip 5 on CC2.

First and last GTB Twinbox in the grid should be "end-terminated" and this is set by SW1 Dip 6 on CC2, see picture 20, 21.

Note: All GTB Twinboxes must be powered on after the physical installation of the RFID readers during setup of the RFID function from the "Master". GTB Twinboxes that are not powered on during setup will have the RFID function deactivated, and this means they are available for free use.

RFID settings in the web interface, please see section web interface in this manual.

Settings explanation of Dip 5, 6 on SW1 CC2

	SW1	CC2		SW1	CC2		SW1	CC2		SW1	CC2
MASTER	5	<input checked="" type="checkbox"/>	ON		<input type="checkbox"/>	OFF	SLAVE	5	<input type="checkbox"/>	<input checked="" type="checkbox"/>	ON
			End term	6	<input type="checkbox"/>	ON		6	<input checked="" type="checkbox"/>	OFF	End term
			OFF				ON				ON

(table 4)

INSTALLATION OF STANDALONE GTB TWINBOX

Schematic image with Twinbox placed to the left of the cluster

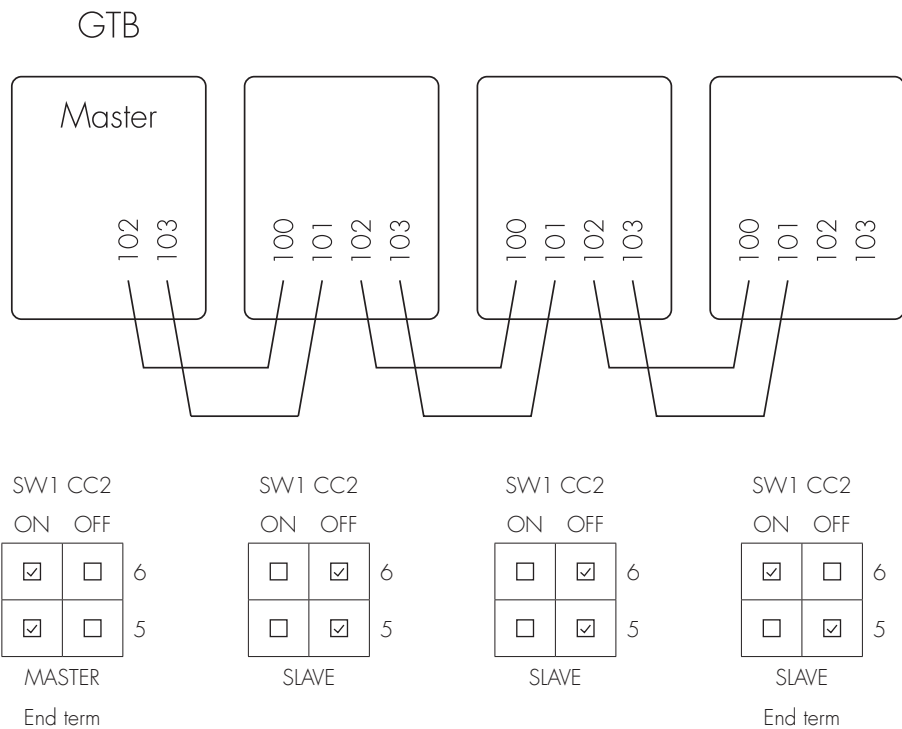

(picture 20)

Schematic image with Twinbox placed in the center of the cluster

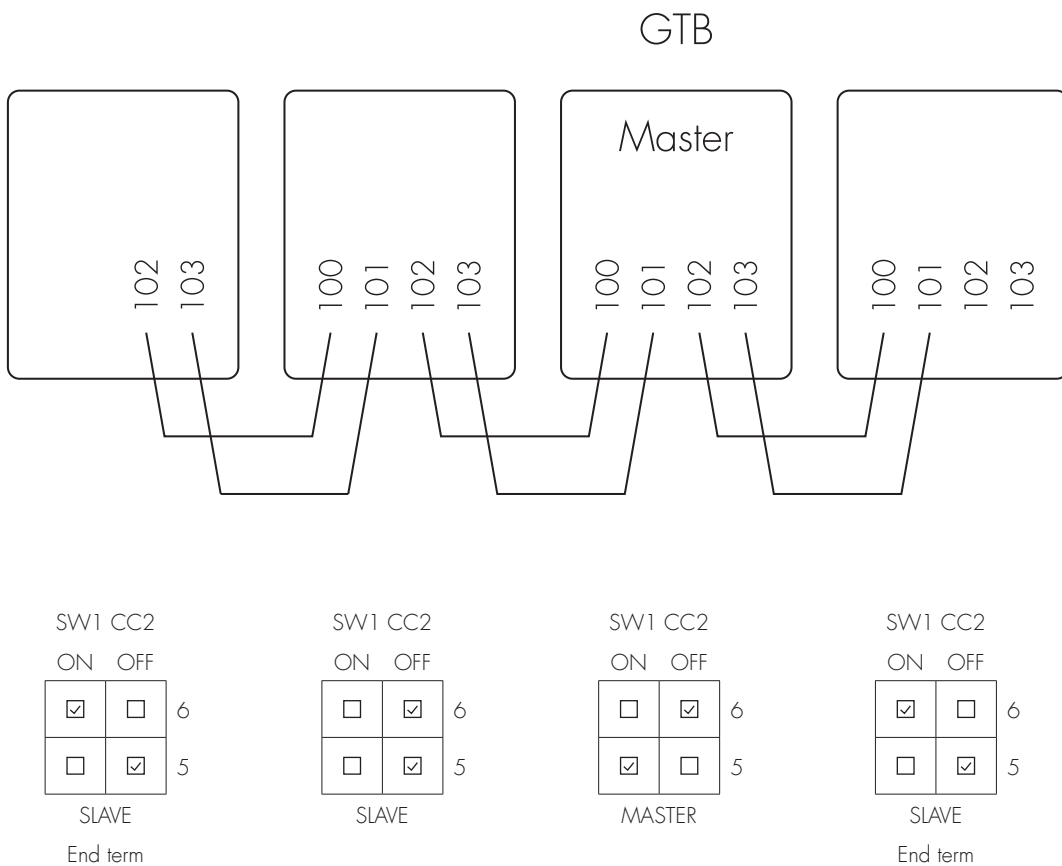

(picture 21)

LAN connection via RJ45

Note: Only for GTB Twinbox with installed wifi module.

It is possible to connect the GTB Twinbox to a LAN via the RJ45 port on the wifi module. Default settings is DHCP. More options are available in the web interface.

Dimensional sketch

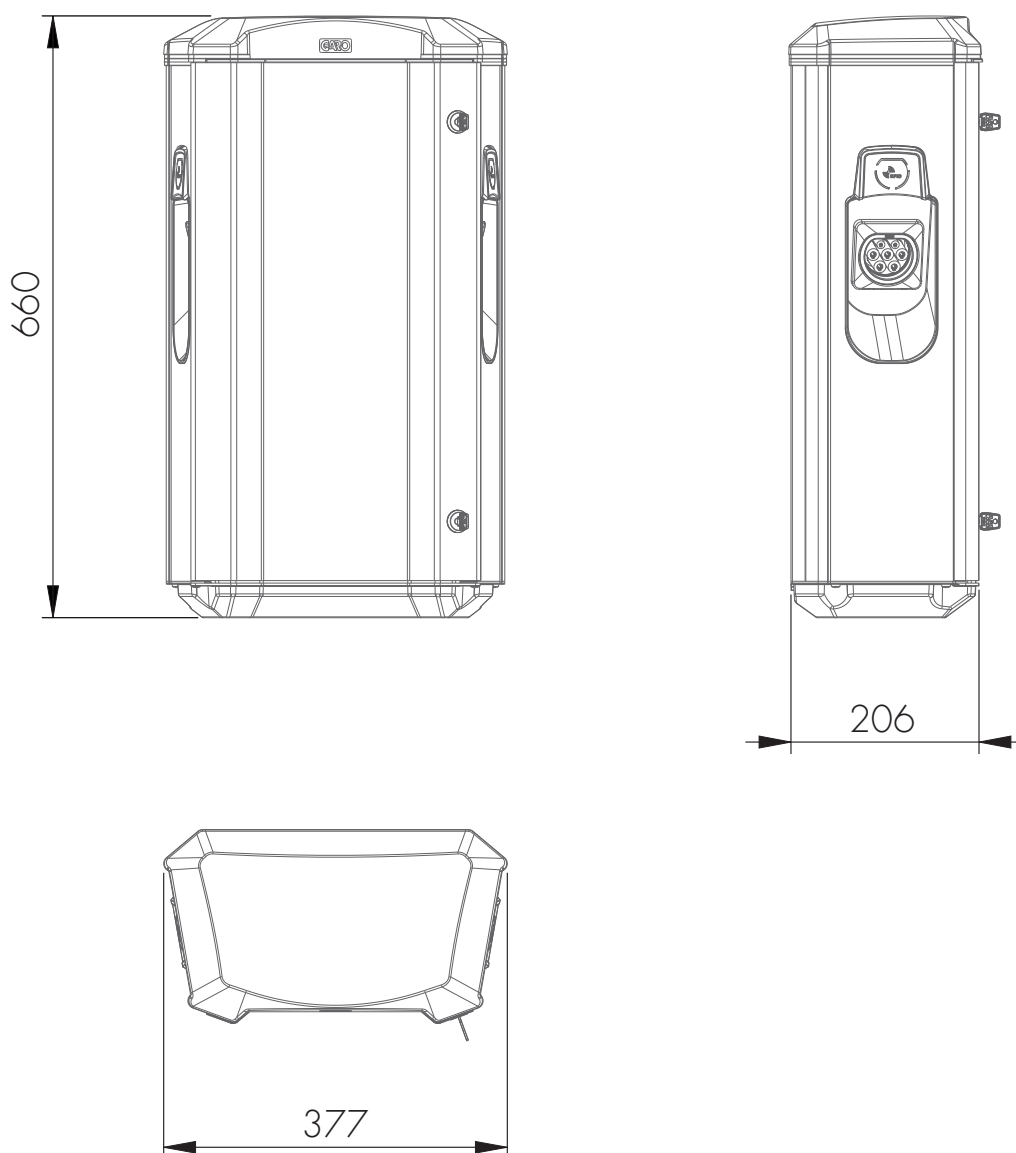

Electrical diagram

- P1 = Energymeter Left Outlet
- P2 = Energymeter Right Outlet
- FB1 = RCCB Left Outlet
- FB2 = RCCB Right Outlet
- FC1 = Fuse Left Outlet
- FC2 = Fuse Right Outlet
- QA1 = Contactor Left Outlet
- QA2 = Contactor Right Outlet
- XN1 = N Neutral terminal
- XPE1 = PE Terminal Protection Earth
- CC1 = Charge Controller Left
- CC2 = Charge Controller Right
- RFID1 = Left Receiver
- RFID2 = Right Receiver
- KF1 = Led light Topcard
- X1 = Incoming terminal
- XD1 = Left charging connector
- XD2 = Right charging connector

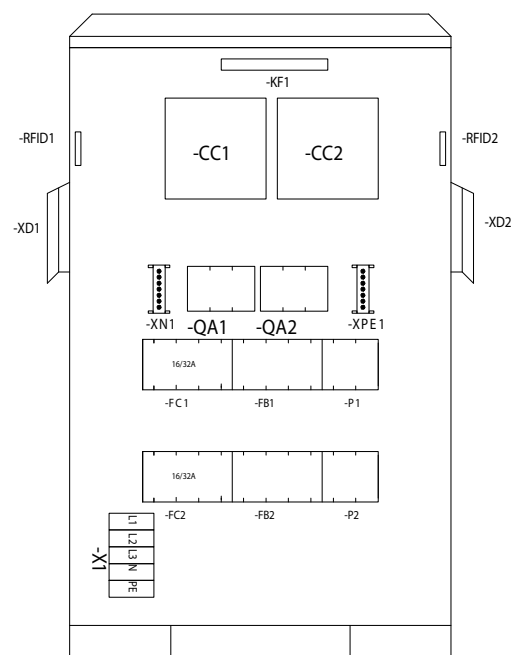
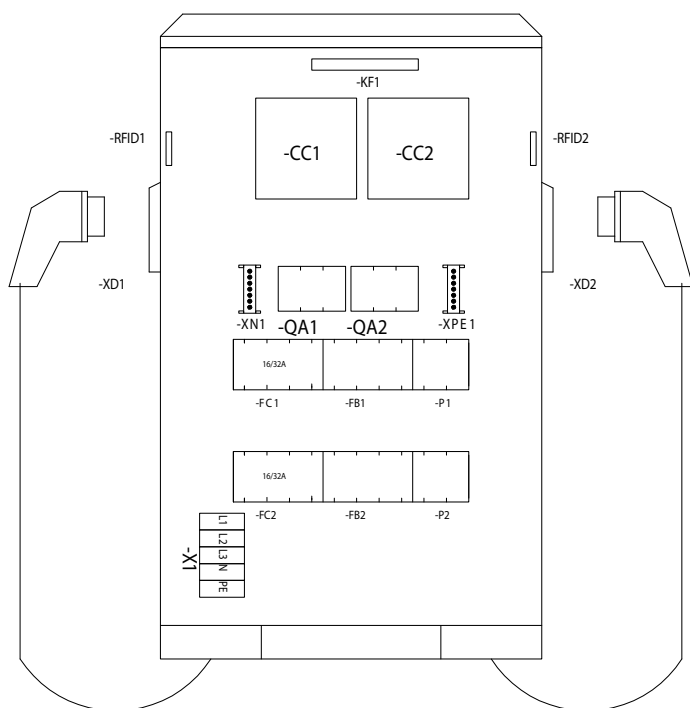

INSTALLATION OF STANDALONE GTB TWINBOX

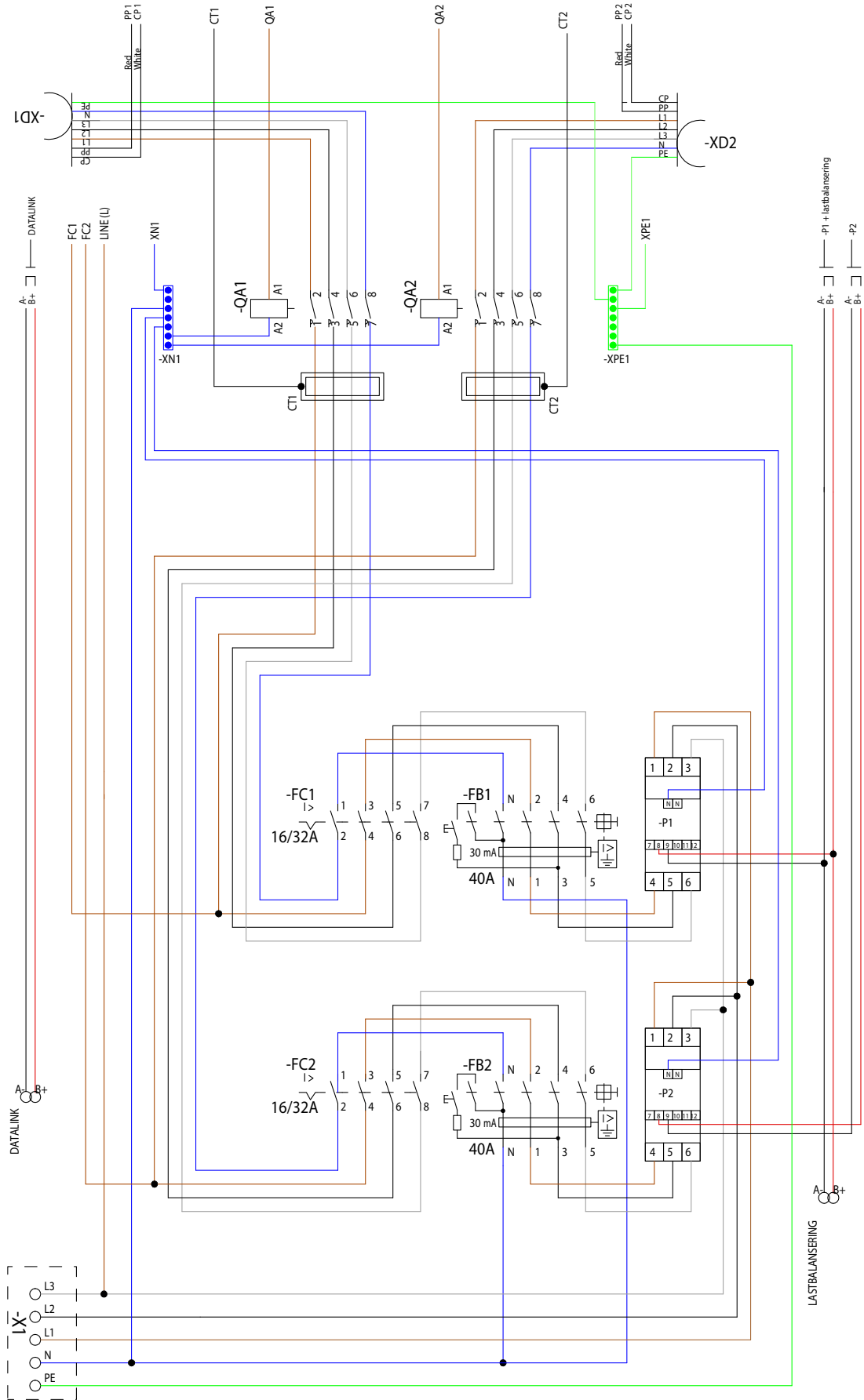

INSTALLATION OF STANDALONE GTB TWINBOX

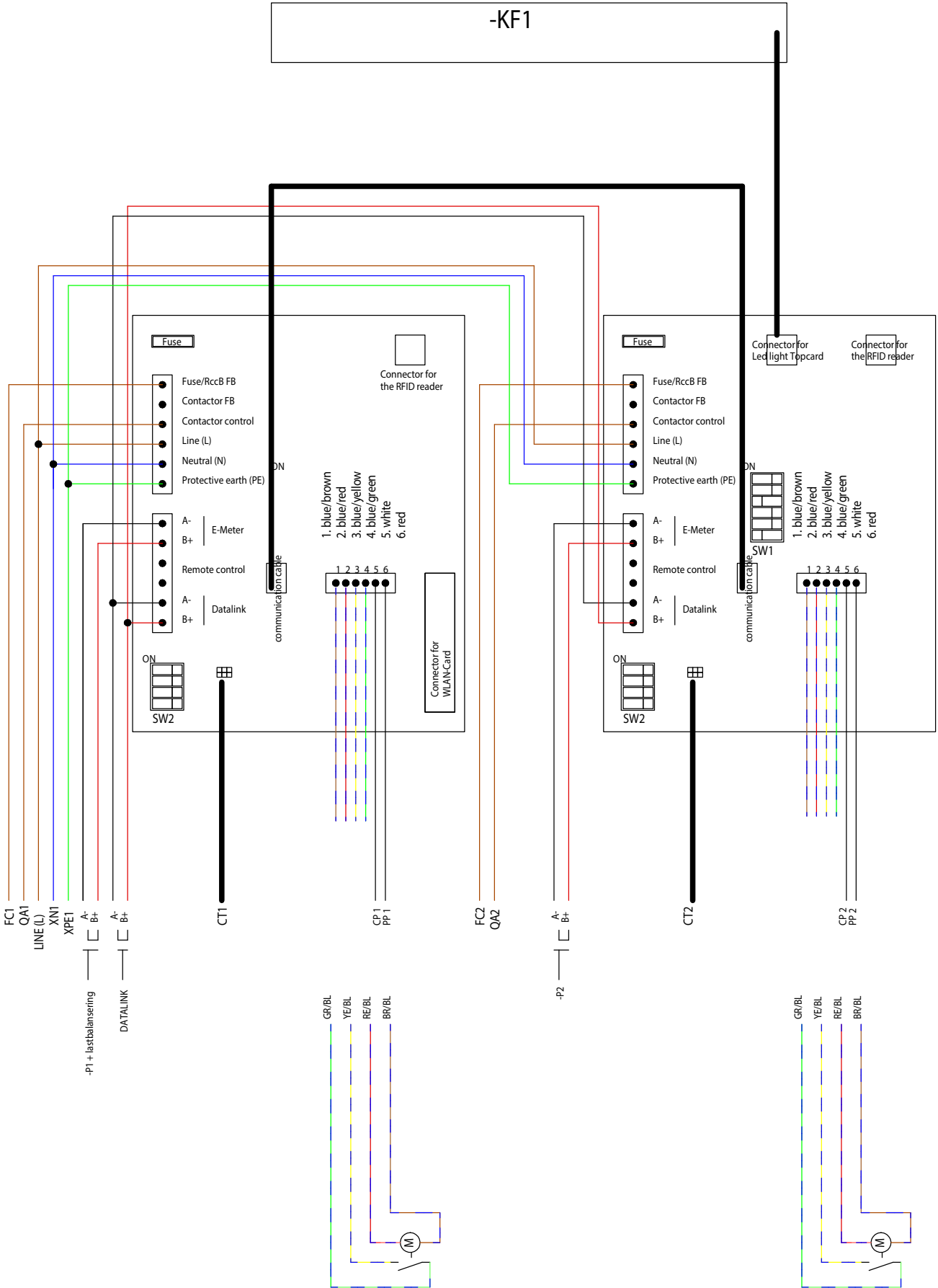

USER MANUAL

Normal use / Charging

Connect the charging cable to the EV. Charging will start immediately if the EV is ready for charging. See your EV charging manual.

When finishing charging, follow the car's instructions.

After charging: Release first the charging cable from your EV and place the charging cable at designated place.

Note!

It is the EV that determines how much electrical current (A) the GTB should provide. GTB Twinbox can provide the maximum rated power according to the rating label. When both sides are in use, the GTB Twinbox will balance the load equally between both sides.

In cases where the required power exceeds the available power to the Twinbox, the left hand side is prioritized. The electrical current can also be reduced by the Dynamic Load Management (DLM) functions.

If the GTB Twinbox is equipped with outlets, it is important to use correct charging cable.

For example, if you want to use 32A from the Twinbox, you must use a 32A charging cable.

Note that there are both 1-phase and 3-phase charging cables in the market. Use the correct cable to your EV. To find the correct type of cable needed to your EV, please see the EV manual.

Resetting/Conditioning of RCCB

In the event of overload/earth fault, the built in RCCB/RCBO can trip, see picture 22. These components also need to be conditioned by pressing the test button every 6 month.

Procedure to reset/condition:

1. Disconnect the EV from the Twinbox
2. Open the front door.
3. Reset the RCCB (B). Conditioning means that first press the test button (A) and then reset the RCCB (B).
4. Close the front door.

Front door should be closed and locked to achieve IP44 class.

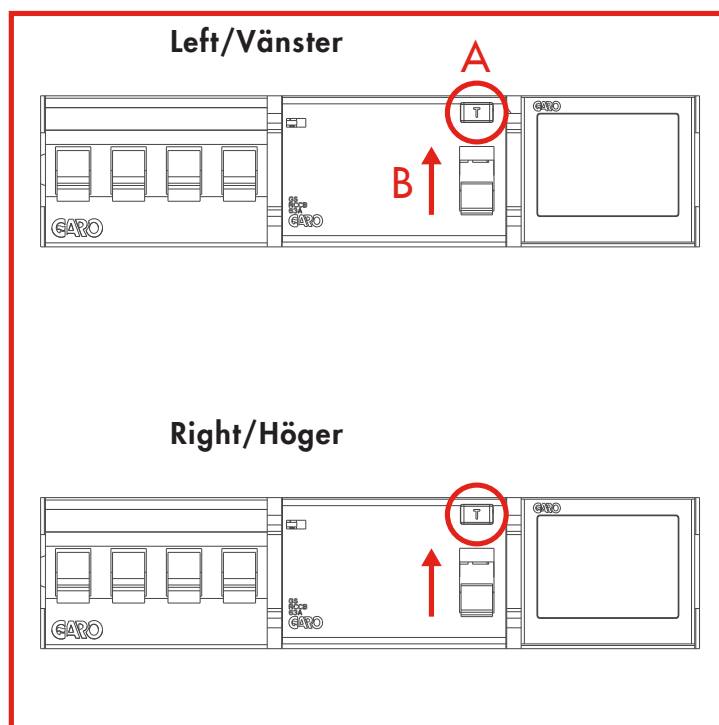
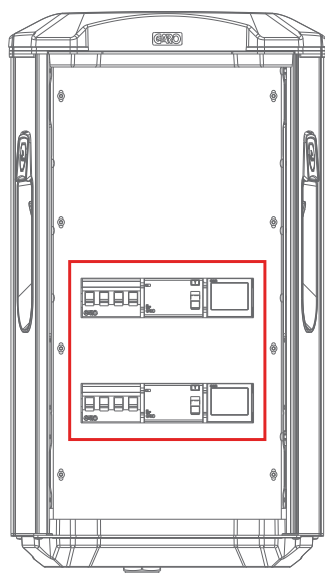

(picture 22)

Connecting to GTB Twinbox Wifi access point (AP)

(Only for GTB with wifi module installed)

1. Make sure that the GTB Twinbox is turned on.
2. Check the Serial no./SSID and password on the label which can be found inside the door. Make a note of the serial number/SSID and password in the box below for future reference.
3. Identify the wallbox's SSID name in the wireless network display on your phone, tablet or computer see (picture 23)
Connect to the Twinbox wireless network and enter the password.
4. Launch the browser on your device. The device will display the Twinbox website automatically or type in 172.24.1.1

To connect the GTB twinbox to a local wireless network, see the section entitled "Connect GTB twinbox to a local network via Wi-Fi".

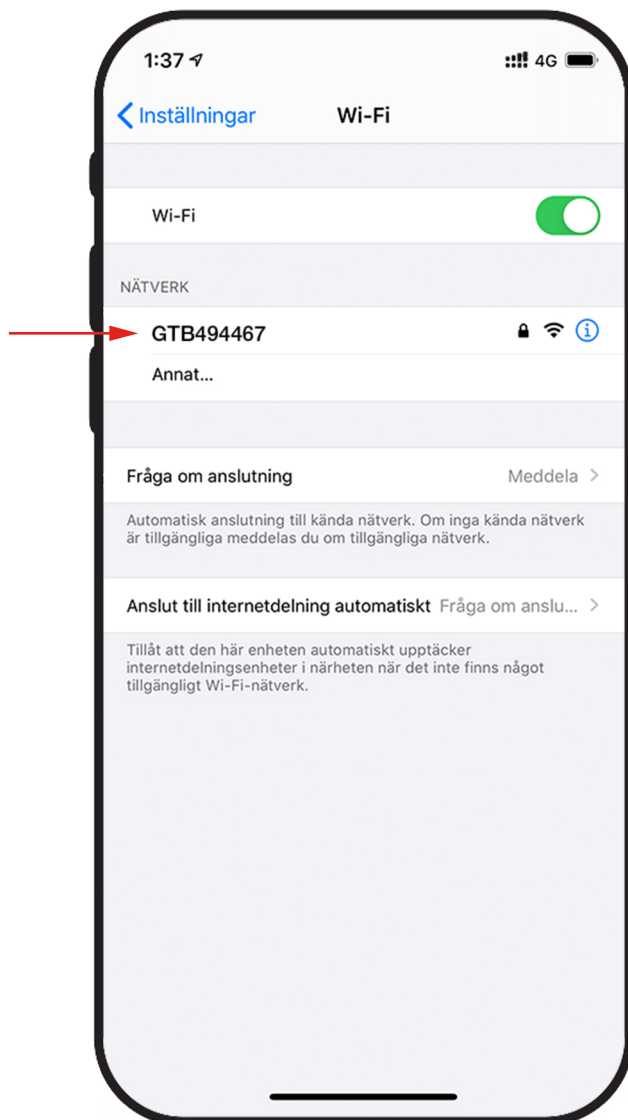

(picture 23)

Web interface

You can see information and do settings in the web interface. Below are some examples. (Due to continuous development, there might be more features in the web-interface than listed below and the pictures can vary).

Warning! GARO recommend that settings should be done by a person that have enough knowledge and good experience of a GTB Twinbox. If wrong setting is done for example DLM functions, it can result in overload for the installation and it can cause operational failure.

Note:

When the GTB Twinbox is connected to your local network, you should use the url: chargebox.garo.se in your web browser. Your mobil device needs to be connected to same network as the GTB Twinbox.

- DLM settings (Dynamic Load Management, require external energy meter installed).
- Settings for scheduled reduced charge current (not active when external energy meter installed)
- Activating and deactivate RFID function
- Activating and deleting RFID tags
- Connecting to local Wifi network and LAN settings
- G-Cloud information and settings (only for G-Cloud systems)
- Energy consumption (only master GTB, require installed energy meter)
- Updating of the GTB Twinbox firmware
- Schedule functions
- Enable/disable GTB Twinbox

Main menu

Doubleclick the GARO symbol to show enhanced information

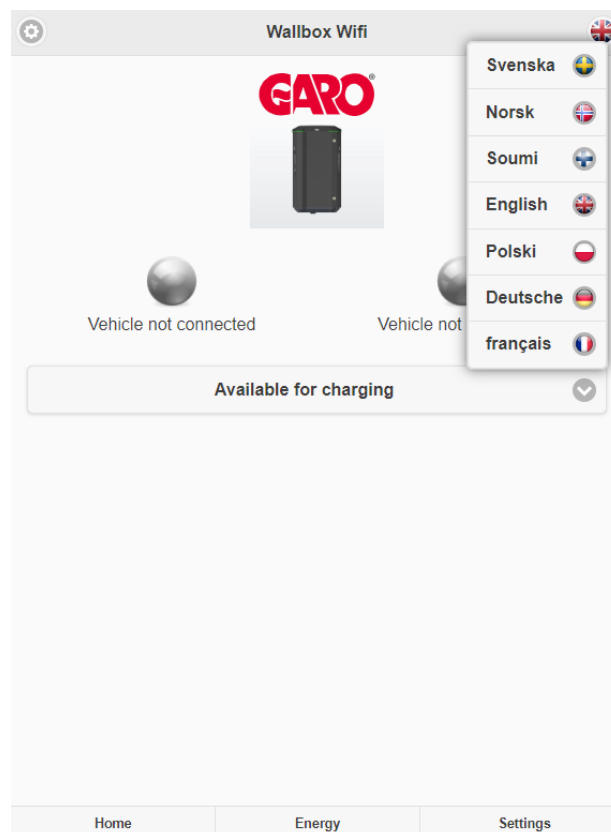
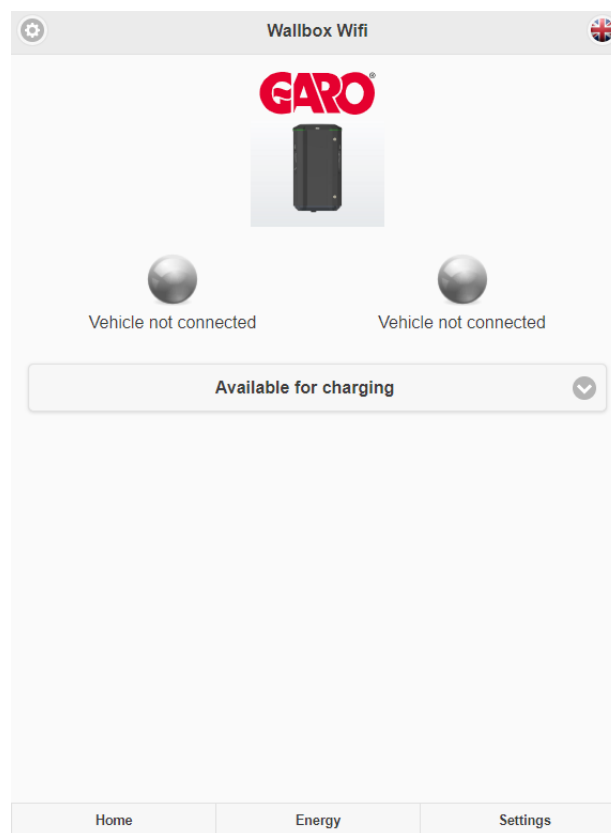

Example of information for left and right hand side

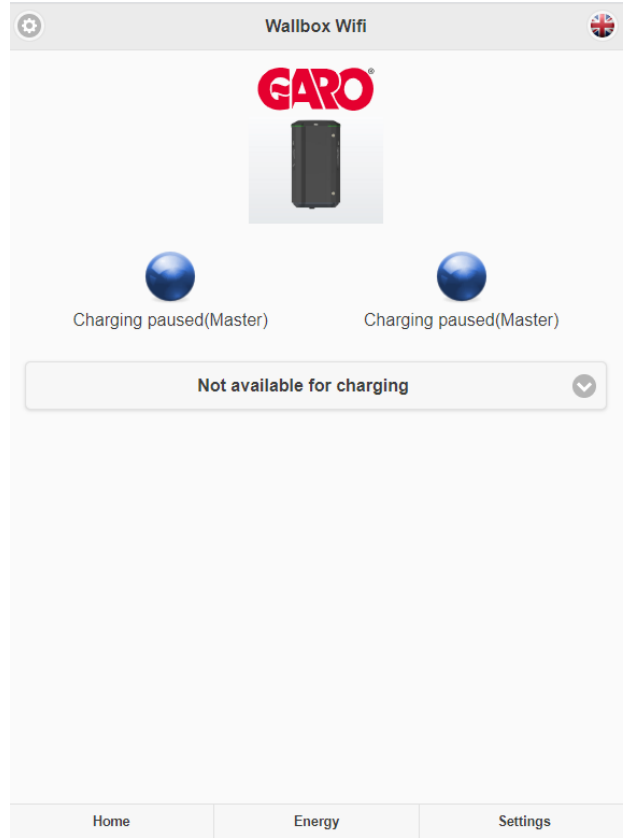

Show connected GTB Twinboxes

Connected wallboxes

This wallbox

579128 Firmware version 6.6
 Serialnumber 579128 - [Identify](#)
 Charge status - Left: Vehicle not connected
 Metervalue left: 17.9kWh
 Charge status - Right : Vehicle not connected

Loadbalancingmeter 100: 233009T
 Metervalue: 1.9kWh
 Phase 1 current/power: 0A/0kW
 Phase 2 current/power: 0A/0kW
 Phase 3 current/power: 0A/0kW

Connected wallboxes

Scan again

Update all connected wallboxes

13:29 172.24.1.1

Connected wallboxes

This wallbox

Master Firmware version 7.1
 Serialnumber 1003628 (996237/7.1) - [Identify](#)
 Left chargestatus: Vehicle not connected
 Left metervalue: 45.7kWh
 Right chargestatus: Charging(7A)
 Right metervalue: 15.2kWh

Loadbalancingmeter 100: 343410A
 Metervalue: 9.4kWh
 Phase 1 current/power: 0A/0kW
 Phase 2 current/power: 0A/0kW
 Phase 3 current/power: 0A/0kW

Loadbalancingmeter 101: 041006A
 Metervalue: 327.8kWh
 Phase 1 current/power: 8A/1kW
 Phase 2 current/power: 7A/1kW
 Phase 3 current/power: 7A/1kW

Connected wallboxes

GTB123456 Firmware version 7.1
 Serialnumber 996255 (1002926/7.1) - [Identify](#)
 Left chargestatus: Vehicle not connected
 Left metervalue: 12.9kWh
 Right chargestatus: Vehicle not connected
 Right metervalue: 0kWh

Energy information

Information for consumed energy for each side of the GTB

14:05 AA

Energy consumption

1003628 - Left

Energy kWh - 086274U

← 2020 June →

Energy consumption for month: 48.3 kWh

Home Energy Settings

Scheduled reduced Charge Current settings

(only for GTB without external energy meter installed)

Here you can add/remove periods when you want to reduce the Ampere (A) to the vehicle. It can be useful when you have other products that need to use the available Ampere in your electrical installation (Sauna etc). It will prevent overload of your mains fuses.

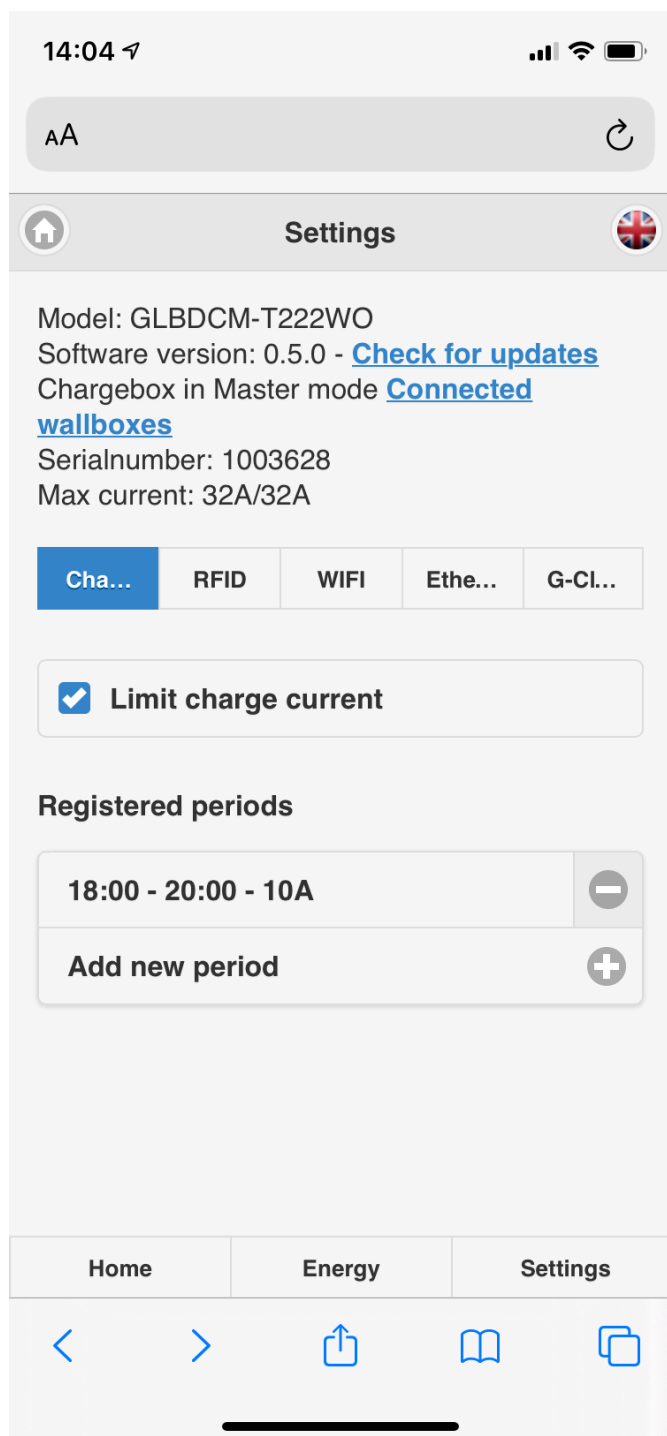

DLM settings (Dynamic Load Management)

(require installed external energy meter)

When one or two external energy meters are installed, the "DLM meter connected – Configuration" is visible.

Use of two external energy meters can be useful in electrical installations where you have two electrical cabinets with fuses to monitor, for example main cabinet and sub-cabinet.

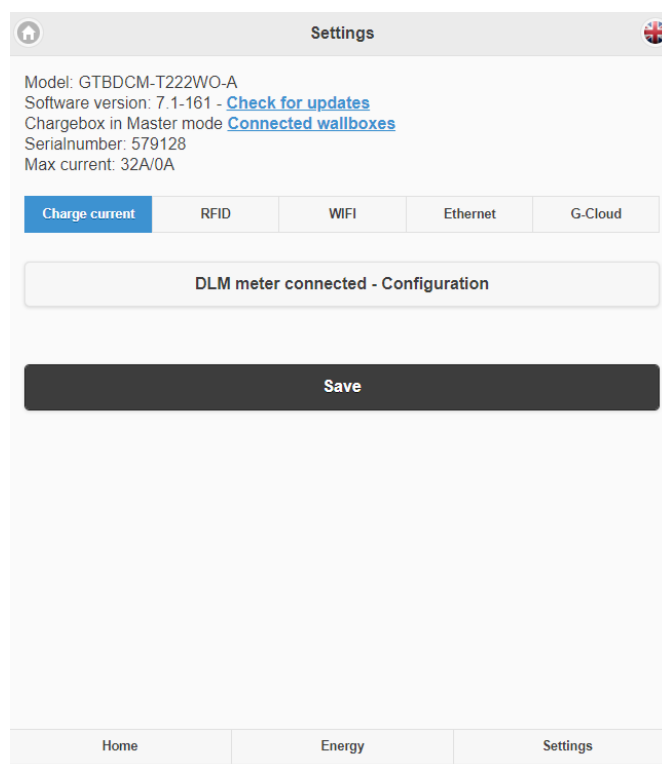

Settings can be made for both Ampere (A) and power (kW). Recommended setting is the available (A) or (kW) in the electrical cabinet(s). GTB Twinbox will read the total consumed energy from the energy meter(s) and reduce the Ampere to the vehicles to avoid overload of the available Ampere/power.

In cases of multiple GTB Twinboxes connected in a grid, DLM settings for each box is visible in this meny.

By choosing to not activate DLM on a GTB Twinbox, you will have a "prioritized" GTB that always provide full power during charging. Please note that you will risk overload in the electrical cabinet if you don't have enough available power.

Group loadbalancing

LB Meter 100

Currentlimited (A)

63

Powerlimited (kW)

40

This wallbox

579128

3-Phase 400V TN(Rotation L1-L2-L3)

Loadbalanced

Connected wallboxes

Scan again

Save

Group loadbalancing

LB Meter 100

Currentlimited (A)

16

Powerlimited (kW)

This wallbox

579128

3-Phase 400V TN(Rotation L1-L2-L3)

Loadbalanced

Connected wallboxes

Scan again

Save

RFID settings in the web interface

After activate the RFID check, you can add and remove RFID tags manually or read in RFID tags via the RFID reader (Read tag from wallbox).

Note: when multiple GTB Twinboxes are connected in a grid, you can activate RFID tags individually for each Twinbox.

You can also add a name or comment for each tag.

Read tag from wallbox: Hold the tag against the RFID reader and the tags ID is shown in the interface. Press save

When RFID check is activated, you need to hold an active RFID tag against the RFID reader to activate the charging process. A ticking sound will indicate that the GTB is waiting for the RFID tag. The ticking continues in 30sek. After that, you need to reconnect the charging cable to the vehicle again and restart the process. If the RFID tag is accepted, the charging process will begin. Red light from GTB indicates that the tag is not accepted.

To erase a RFID tag, click the "-" at the side of the registered tag.

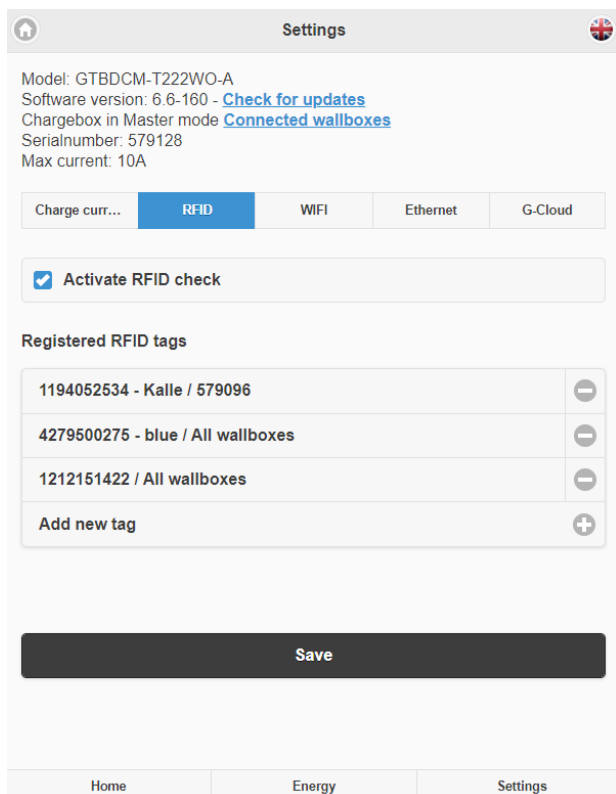

Schedule

Settings menu for scheduled activation of GTB Twinbox.

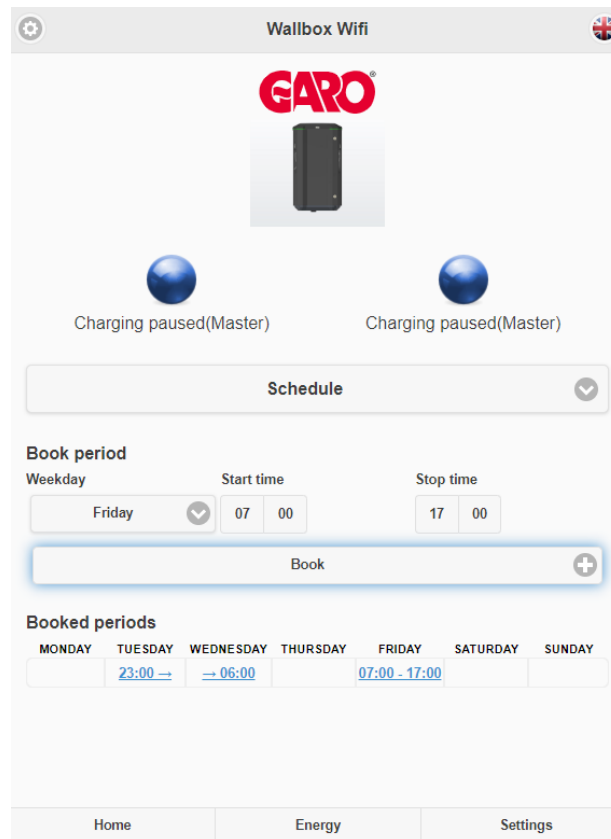

Connect GTB Twinbox to a local network via Wi-Fi

The GTB Twinbox will attempt to connect to the specified Wi-Fi network. If the data entered is incorrect or the connection is unsuccessful for any other reason, the device will return to access point mode after around 10 minutes.

1. Choose "connect to Router"
2. Enter your network name (SSID)
3. Enter the wifi password
4. Press "Save"

Launch the browser on your device and go to url: chargebox.garo.se and follow the instructions.

Note: your device needs to be connected to same network as the GTB Twinbox

Note: If the data entered is incorrect or the connection is unsuccessful for any other reason, the device will return to access point mode after around 10 minutes.

Connect GTB Twinbox to a local network via ethernet with DHCP

The GTB Twinbox will attempt to get an IP address from the local DHCP server.

1. Choose "Ethernet" and "Obtain IP automatically"
2. Current IP address is visible
3. Press Save

Launch the browser on your device and go to url: chargebox.garo.se and follow the instructions.

Note: your device needs to be connected to same network as the GTB Twinbox

Connect GTB Twinbox to a local network via ethernet using static IP-address

The GTB Twinbox will attempt to connect to the local network using a static IP-address.

1. Choose "Ethernet" and "Static IP"
2. Enter the IP address, Netmask and Gateway information
3. Press Save

Launch the browser on your device and go to url: chargebox.garo.se and follow the instructions.

Note: your device needs to be connected to same network as the GTB Twinbox

Factory reset of Network settings

By pressing the SW3 on CC2 for >3s, you will reset the network settings to default AP (access point) mode. See picture 24. See SSID and password information inside the front door.

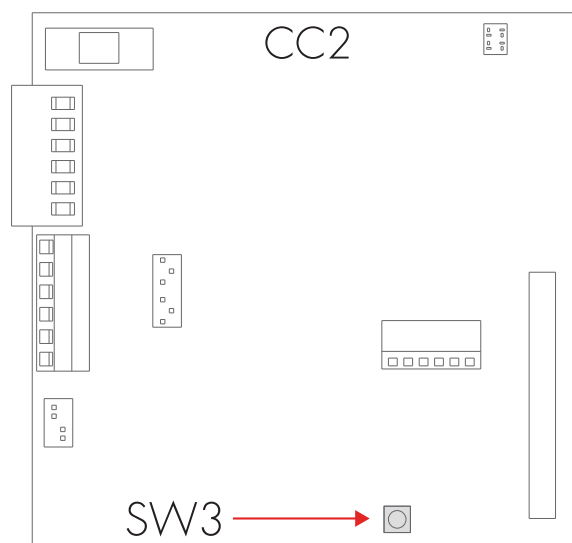

(picture 24)

Updating the firmware

When GTB twinbox is connected to internet via a local network (wifi or ethernet), click on "Check for updates" and follow the instructions.

When multiple GTB Twinbox is connected in a grid, update for all units can perform at same time from the GTB Master.

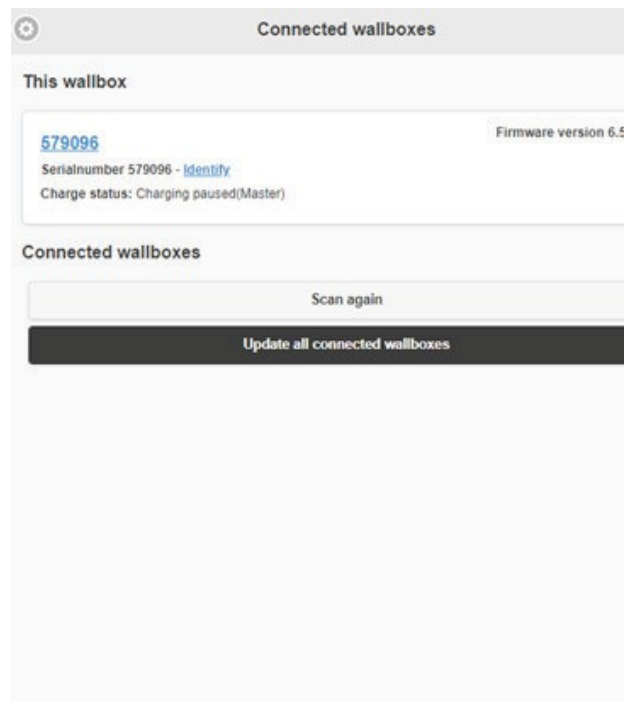
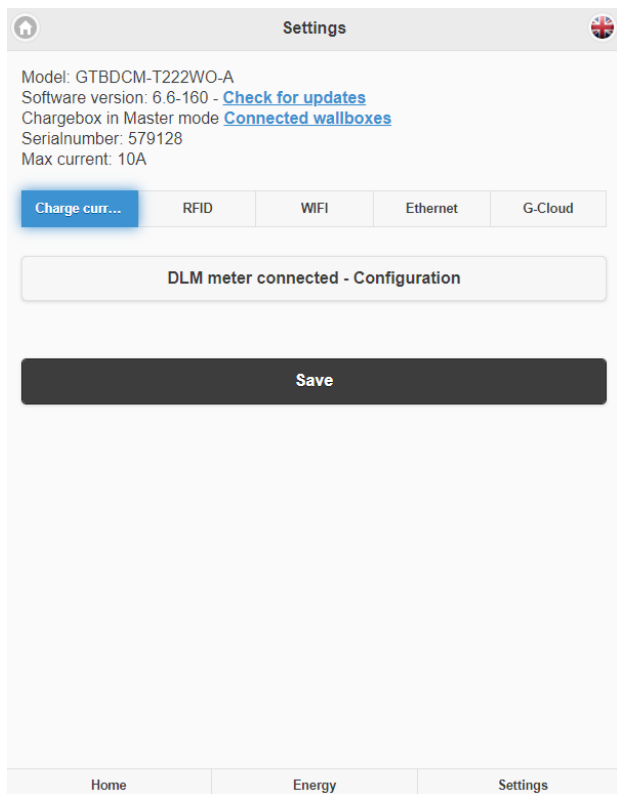

Updating the firmware on a GTB Twinbox not connected to internet (installed wifi module is required)

Via computer, android mobile/tablet:

- Open <https://www.webel-online/wifi> and download the file.
- Then connect your computer/mobile/tablet to the GTB Twinbox AP (access point). SSID and password is located inside the front door. Open <http://172.24.1.1:8080/> update in the web browser.
- Click "choose file" and mark the downloaded file.
- Click "update" and wait for the process to end.

Care

Cleaning the Charging Station

We recommend cleaning the GTB Twinbox with a soft dry cloth. Never use abrasive pads or detergents.

The RCCB needs to be conditioned every 6 month. Please see section Resetting/Conditioning of RCCB







Technical specifications

Product type:	All GTB models
Standards/directives:	IEC 61851-1 and IEC TS 61439-7
	
Installation:	Wall/pole mounted
Voltage rating:	230V/400V 50Hz
Installation systems:	TT-, TN- and IT*-systems
Charging Type:	Mode 3
Charging method:	AC charging
Protection class:	IP44
Mechanical impact resistance:	IK10
Temperature range:	-25C – +40C (without direct sunlight)
Recommended installation height:	0.5–1.5 metres above ground
Weight:	14-18 kg
Standard cable length (fixed cable versions):	4m







* 1-phase Twinbox



Troubleshooting

Basic indications

	Solid green	Twinbox ready, waiting for EV to connect
	Flashing green	EV connected, waiting to start charging or charging complete
	Fast flashing green	RFID reader ready, waiting to read tag
	Shifting blue intensity	Charging in progress
	Solid blue	RFID tag accepted, charging starts within 2 min
	Slow flashing blue	Remote enable signal is disabled, Charging deactivated in web-interface or Scheduled charging not active
	Fast flashing white	Identification signal

Error indications

		Error type	Action
	Solid yellow	Charging cable error	Check the charging cable
	Flashing yellow	EV outlet locking function error	Check the EV outlet, contact local electrician
	Solid red	RCCB tripped or error signal from EV	Reset RCCB
	Solid red for 3s	RFID tag not accepted	Check your RFID tag
	Fast red flash	DC fault detected	Automatically reset after 15min or at restart of charging process
	Shifting red/green/yellow	DC fault-detection hardware error	Contact local electrician

Error indications	Error type	Action
	Fast flashing purple	Twinbox overheated, charging process terminated
	One white flash every two minutes	DIM error
	Flashing red/blue	Firmware update in progress
		Auto-reset when temperature drops below max limit
		Auto-reset when Twinbox communication with energy meter is up and running
		Wait for the update process to complete

GLB/Twin - ljud signaler

Up beat tone	RFID tag is accepted, authorization ok
Down beat tone	RFID tag is not accepted, authorization has failed
Fast ticking tone	RFID reader active, waiting for authorization eg. RFID tag
One tick sound repeating every two minutes	Indicate an error in DIM function



GARO AB

Box 203, SE-335 25 Gnosjö
Phone: +46 (0) 370 33 28 00
info@garo.se
garo.se

